

PROCESSING TECHNOLOGIES

LIPH-ADTM

Liquid Phase Anaerobic digestion

TECHNOLOGY
PROFILE 2022
Prepared By ORSPL



**ORGANIC RECYCLING
SYSTEMS PVT. LTD**

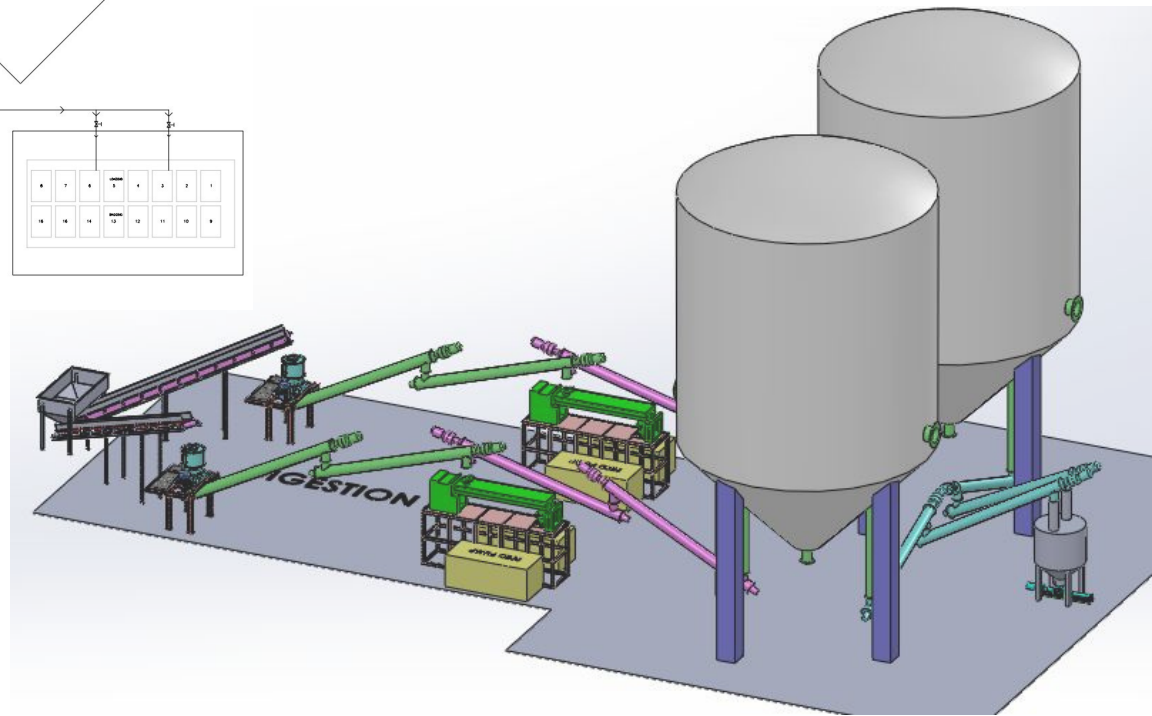
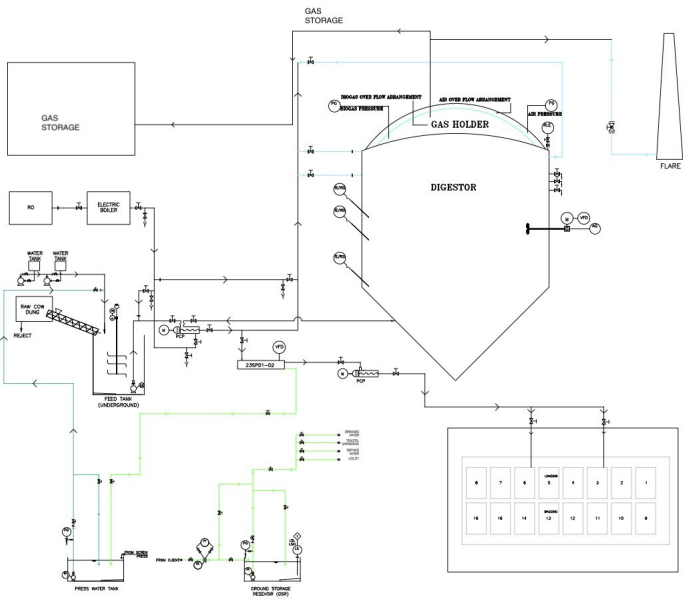

Liquid Phase Anaerobic Digestion

- Low cost solution with easy operation.
- Temperature control digester.
- Works under varying weather conditions.
- Suitable for kitchen waste, press-mud, animal dung, organic fraction with low Total solid content.
- Easy Integration with segregation line and post treatment system.
- Biogas generated can be used for power, vehicular or cooking fuel, heating and refrigeration
- Suitable for capacities below 50 Tons per day processing.