

PROCESSING TECHNOLOGIES

INV-COTM

INVESSEL COMPOSTING TECHNOLOGY

TECHNOLOGY
PROFILE 2022
Prepared By ORSPL



**ORGANIC RECYCLING
SYSTEMS PVT. LTD**

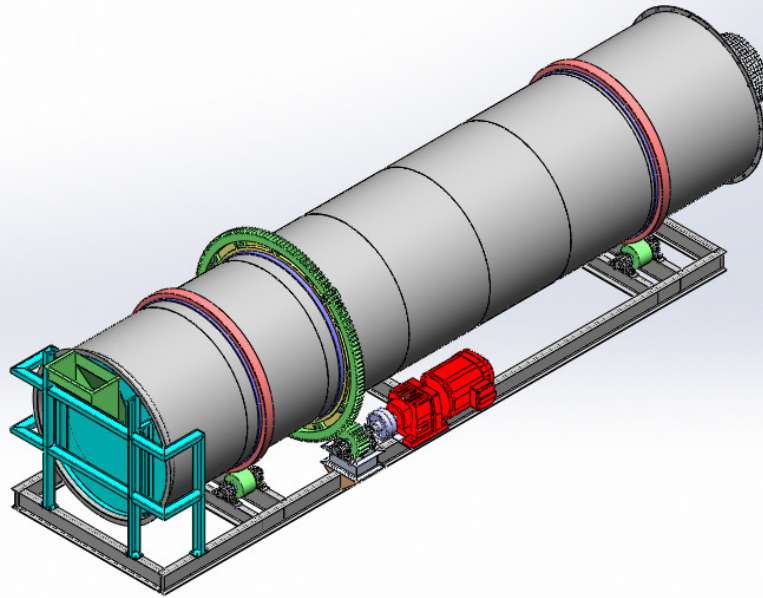

INVESSEL COMPOSTING

- Engineered as per Invessel composting guidelines.
- Lower or nil metal leaching due to pre-segregation and pulverising before composting.
- Temperature control to reduce pathogen impact.
- Works under varying weather conditions.
- Suitable for Unsegregated OFMSW and Segregated organic waste.
- Easy Integration with segregation line and post enhancement system.
- Compost as per Fertiliser control order.
- Suitable for capacities above 10 Tons per day processing.
- Odour free and requires lower footprint.
- Reduced Curing time.